

# PROGRESSIVE DESK

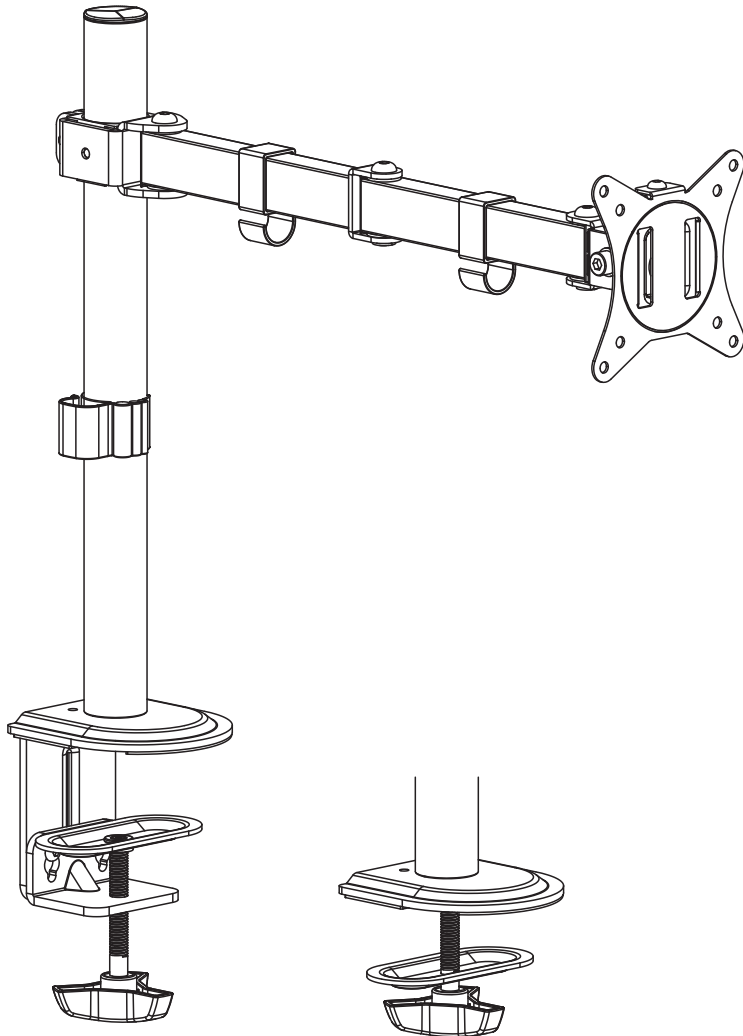

17"-32"  
Screen Size

RATED  
9kg/19.8lbs

VESA  
75x75 100x100

+45°--45°

+90°--90°

360°

Cable Management



Scan for more information

## DM-04-1

---

## User Manual

V 1.1

# Table of Contents





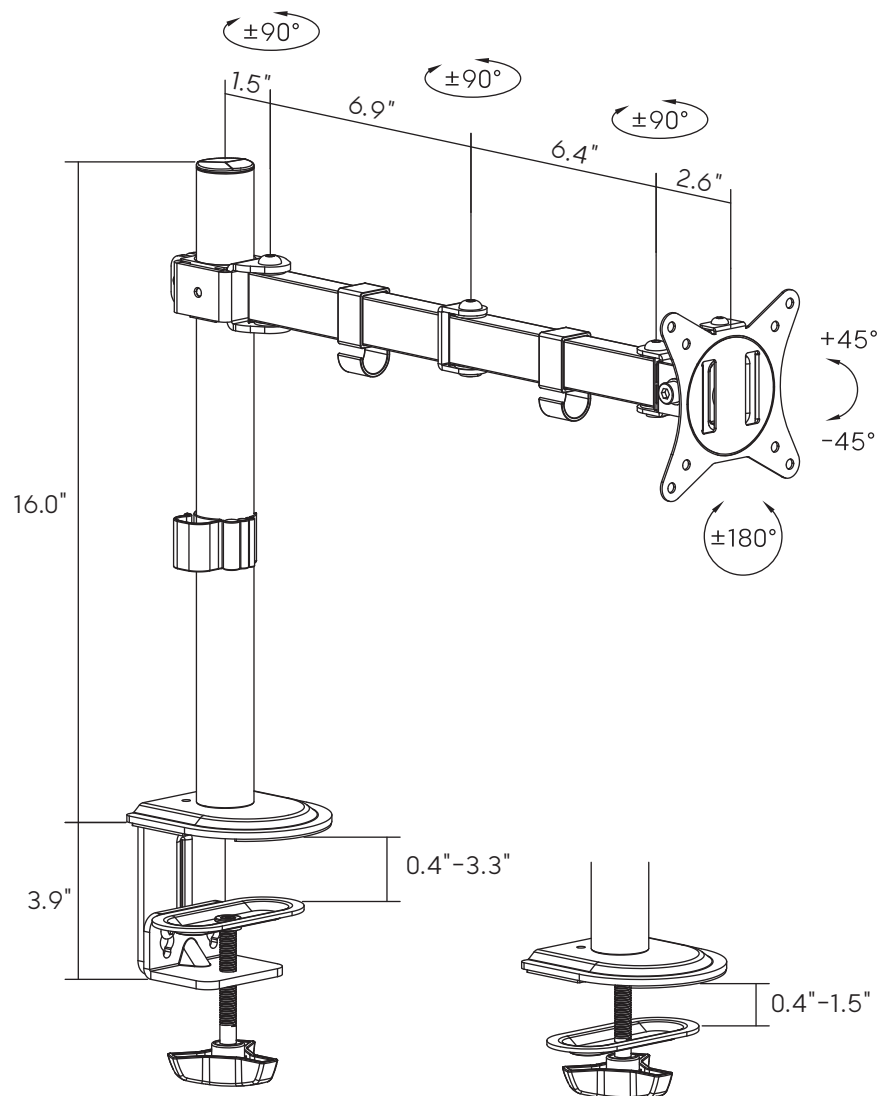

Specifications .....	3
Parts List .....	4
Assembly & Installation .....	5



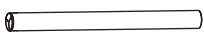

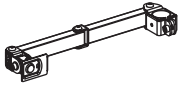

# Specifications



Monitor Compatibility	Up to 32"
Weight Capacity	19.8 lbs.
Product Weight	5.7 lbs.
Clamp Desk Thickness	0.4" to 3.3"
Grommet Desk Thickness	0.4" to 1.5"
Grommet Hole Diameter	0.4" to 3.2"
Cable Management	Cable Cover, Cable Hooks
VESA Compatibility	100mm × 100mm and 75mm × 75mm
Base Joint Rotation	±90°
Elbow Joint Rotation	±90°
Neck Joint Rotation	±90°
VESA Mount Rotation	±180°
Monitor Tilt Adjustment	±45°
Height Adjustment	Up to 15.25"
Clamp Mount	Included
Grommet Mount	Included
Detachable VESA	Included



# Parts List

No.	Part	Qty.
A1	 Base Plate	1
A2	 Mounting Pole	1
A3	 Bracket	1
A4	 Clamp	1
A5	 Arm	1
A6	 Cable Hooks	2
A7	 Cable Cover	1
A8	 VESA Plate	1

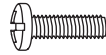
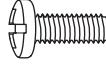
No.	Part	Qty.
B1	 M5x16 Screw	1
B2	 M10x20 Screw	1
B3	 M6x10 Screws	3
B4	 4mm Hex Key	1
B5	 6mm Hex Key	1
B6	 Philips Head Screwdriver	1

No.	Part	Qty.
M-A	 M4x12 Screws	4
M-B	 M5x12 Screws	4
M-C	 Washers	4

# Assembly & Installation

## Step 1: Attach the Base Plate

Attach the Base Plate (A1) to the Mounting Pole (A2) using the M5x16 Screw (B1). Ensure the largest center holes on each part are aligned. Tighten with the Philips Head Screwdriver (B6).

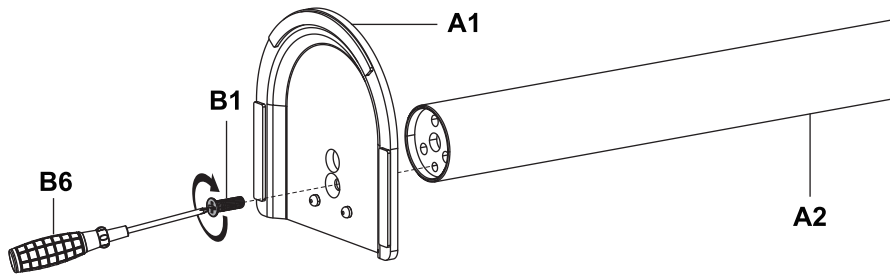

## Step 2: Choose Installation Method (Clamp or Grommet)



Option 1: Clamp

Option 2: Grommet

### Option 1: Clamp – Mount to Side of Desk (Page 6)

Requirements: Desk Thickness 0.4" to 3.3"

### Option 2: Grommet – Install into Grommet Hole or Drilled Hole (Page 8)

Requirements: Desk Thickness 0.4" to 1.5", Desk Hole Diameter 0.4" to 3.2"

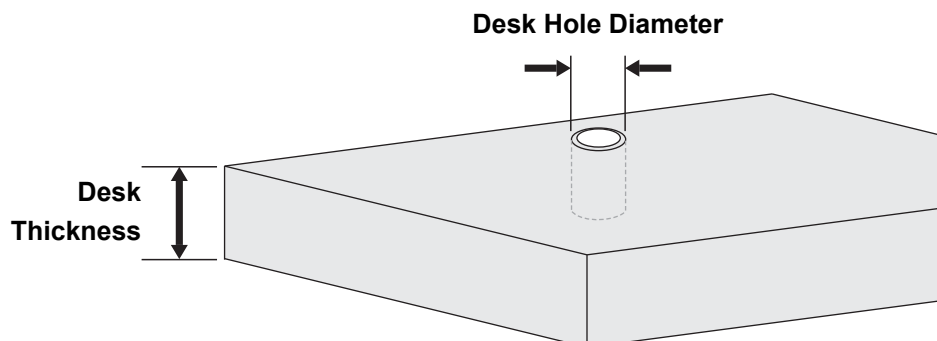

# Assembly & Installation

## Option 1: Clamp – Mount to Side of Desk

**Step 2A:** Align Bracket (A3) with the studs on the Base Plate (A1) and attach using the M10x20 Screw (B2). Tighten with 6mm Hex Key (B5).

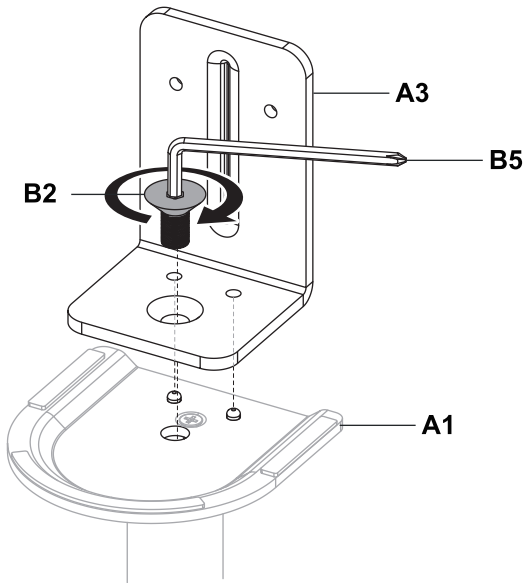

**Step 2B:** Insert 2x M6x10 Screws (B3) into the Bracket (A3) using the 4mm Hex Key (B4). **DO NOT TIGHTEN** the screws. Leave at least a 3/16" gap for Step 2D.

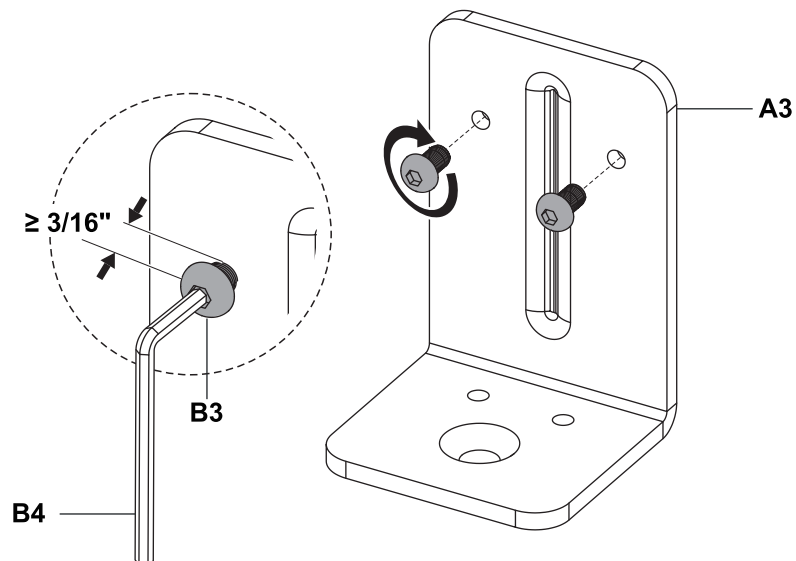

# Assembly & Installation

## Step 2C: For tabletop thickness 0.4" to 1.75" skip to Step 2D.

For tabletop thickness 1.75" to 3.3", unscrew the preinstalled screw on the Clamp (A4) using the Philips Head Screwdriver (B6). Separate the clamp components, flip the small bracket, and put the parts back together. Tighten the screw using the Philips Head Screwdriver (B6).

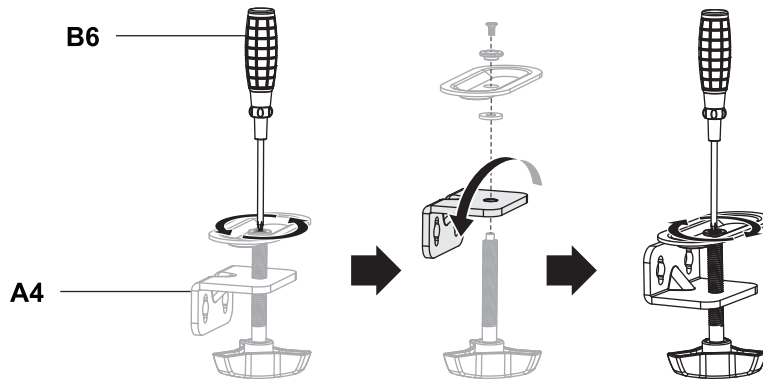

**Step 2D:** Hook on Clamp (A4) to the loose screws from Step 2B. Tighten both M6x10 Screws (B3) using the 4mm Hex Key (B4).

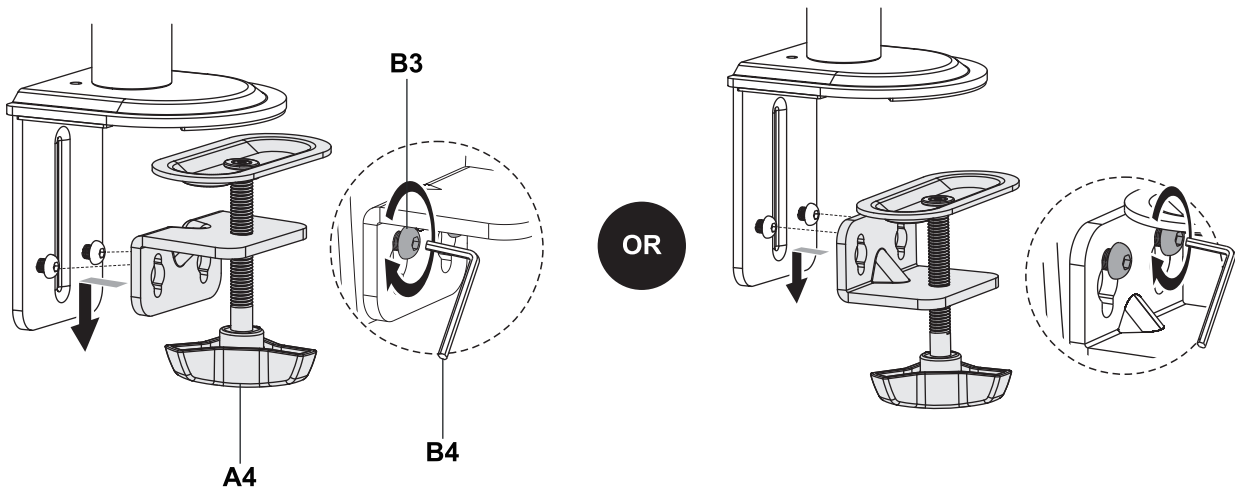

**Step 2E:** Place the assembly on your desired tabletop location and secure by tightening the clamp knob.

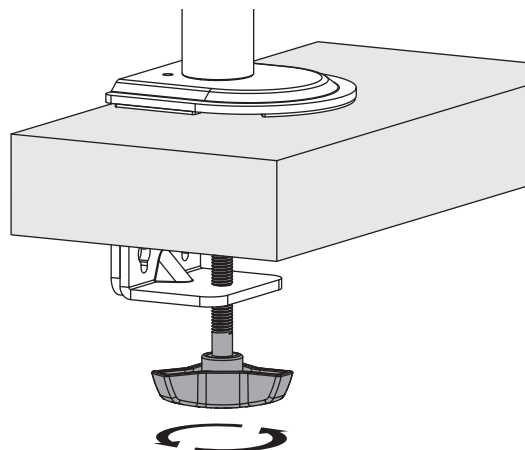

# Assembly & Installation

## Option 2: Grommet – Install into Grommet Hole or Drilled Hole

**Step 2A:** Separate the components from Clamp (A4) by using the Philips Head Screwdriver (B6). Put the mounting plate onto the threaded knob screw.

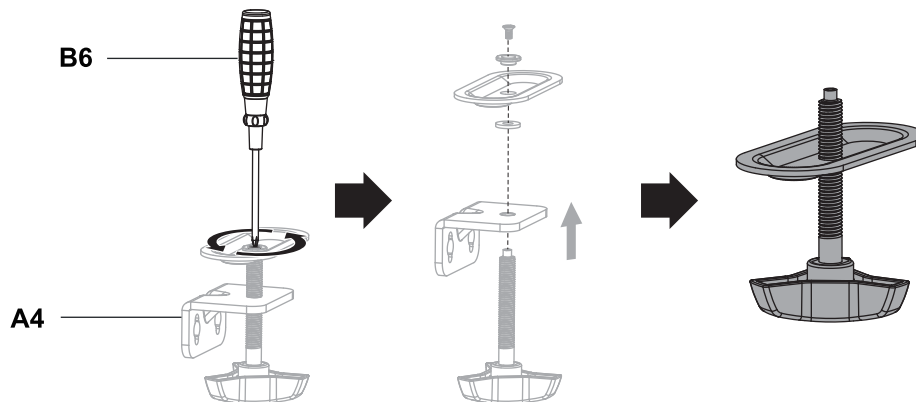

**Step 2B (Optional):** For installations on a tabletop WITHOUT a grommet hole or predrilled hole, use a drill with a 3/8" drill bit.

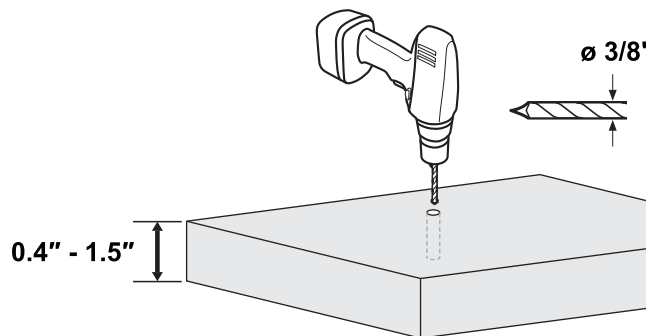

**Step 2C:** Insert the threaded knob screw and plate into the bottom side of the tabletop. Align with the hole on the base plate assembly. Tighten the knob to secure the monitor stand to the tabletop.

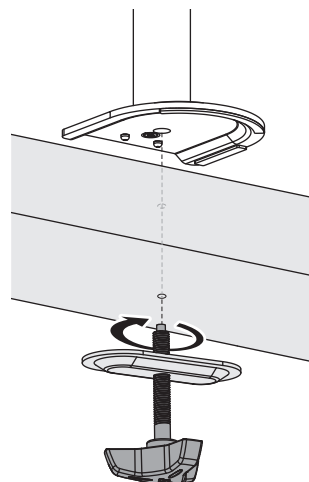



# Assembly & Installation

## Step 3: Position the VESA Mount

**Step 3A:** Slide the VESA Plate (A8) onto the VESA mount of the Arm (A5).

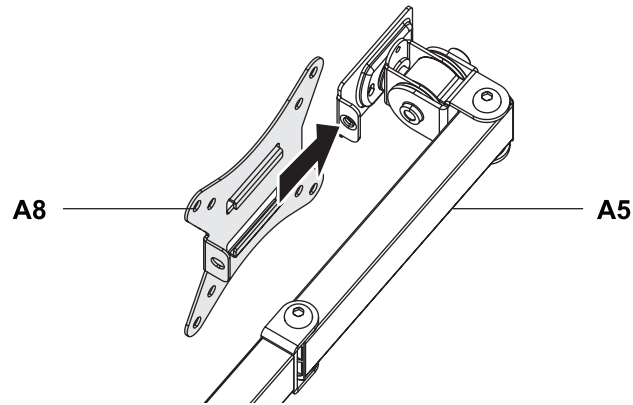

**Step 3B:** Rotate the VESA mount 90 degrees so that the connector is facing up as seen below.

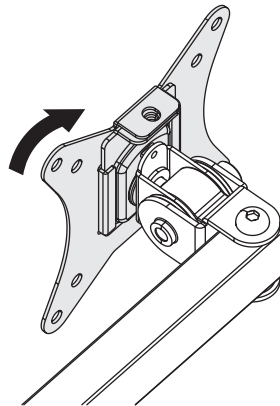

**Step 3C:** Remove the VESA Plate (A8) from the Arm (A5) and set aside for Step 6.

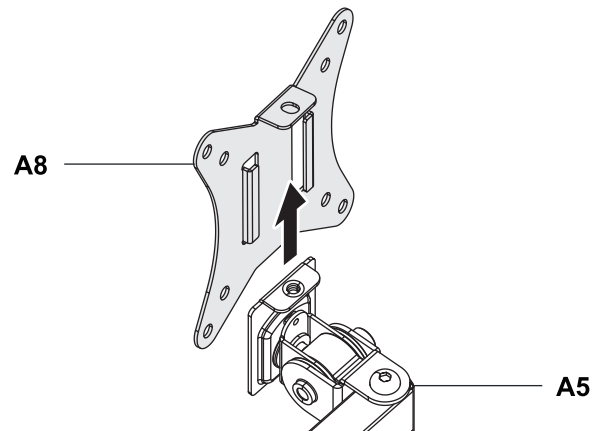

# Assembly & Installation

## Step 4: Install the Arm

**Step 4A:** Place the Arm (A5) on the Mounting Pole (A2).

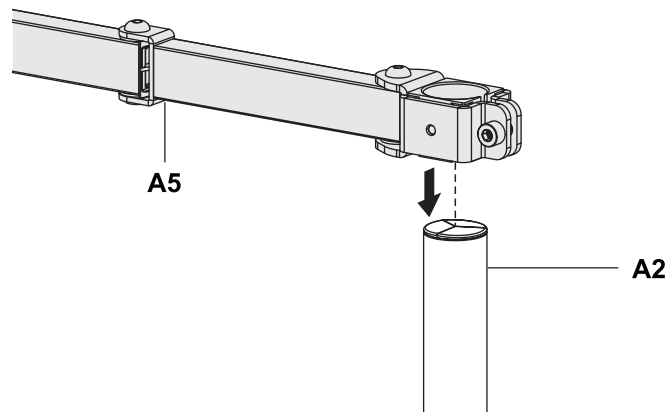

**Step 4B:** Secure the Arm (A5) at the desired height by tightening the preinstalled screw with the 6mm Hex Key (B5).

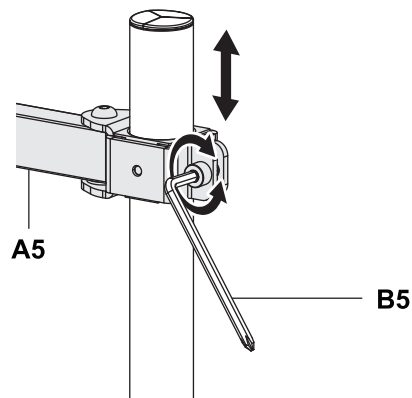

## Step 5: Attach the Cable Management Hooks and Cover

**Step 5A:** Attach 2x Cable Hooks (A6) to the Arm (A5).

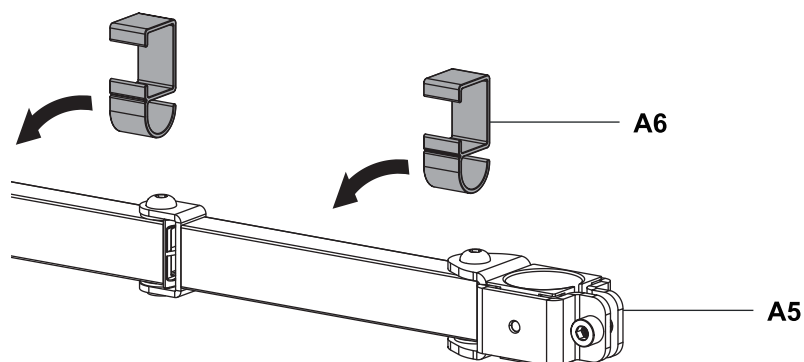

# Assembly & Installation

**Step 5B:** Attach the Cable Cover (A7) to the Mounting Pole (A2).

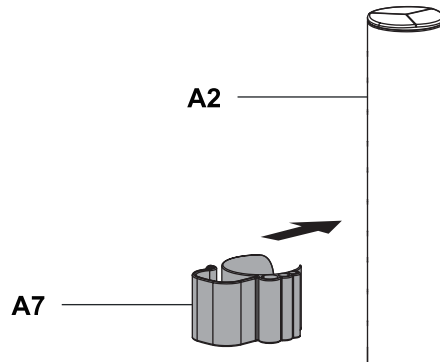

## Step 6: Install VESA Plate to the Monitor

Install a VESA Plate (A8) to your desired VESA compatible monitor. Align the VESA Plate (A8) with the top of the monitor. Ensure the flange is facing away from the monitor and towards the top as seen below. Use Washers (M-C) and compatible screws (M-A or M-B) with the monitor.

**DO NOT OVERTIGHTEN!** Secure the parts using the Philips Head Screwdriver (B6).

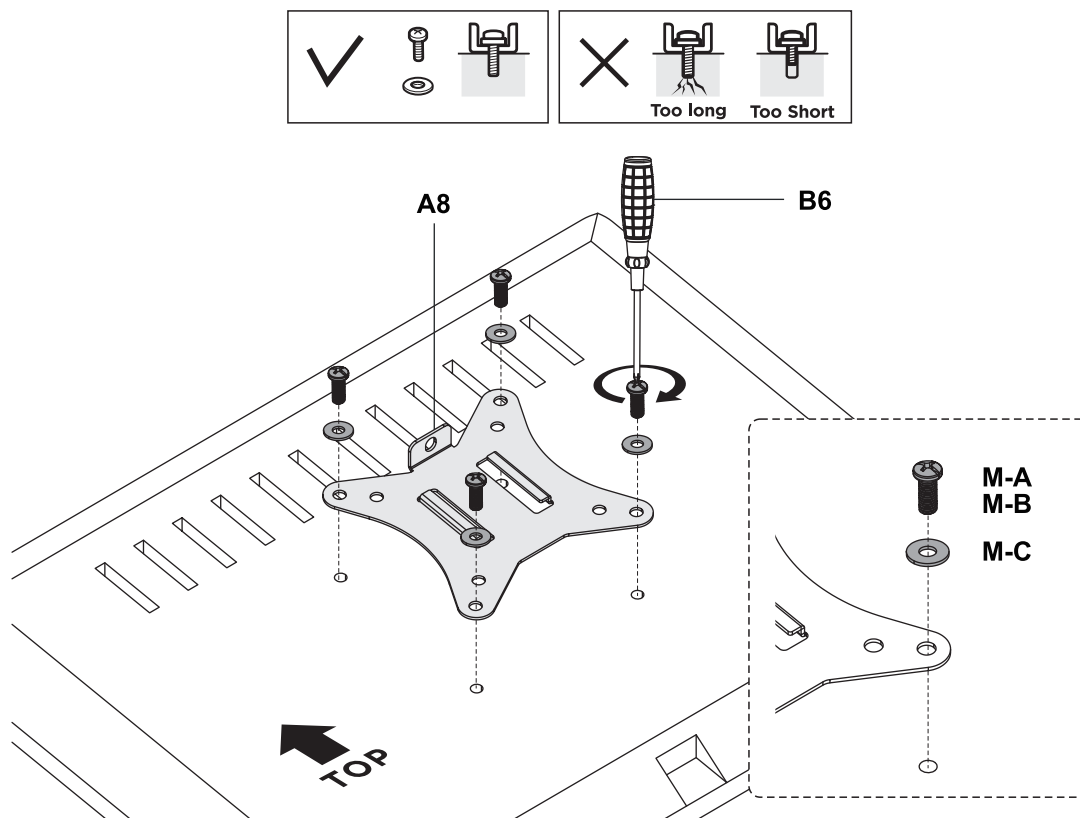

# Assembly & Installation

## Step 7: Slide the VESA Plate onto the Arm

Slide the VESA Plate (A8) and monitor onto the Arm (A5). Secure the monitor using the M6x10 Screw (B3) and tighten with the 4mm Hex Key (B4).

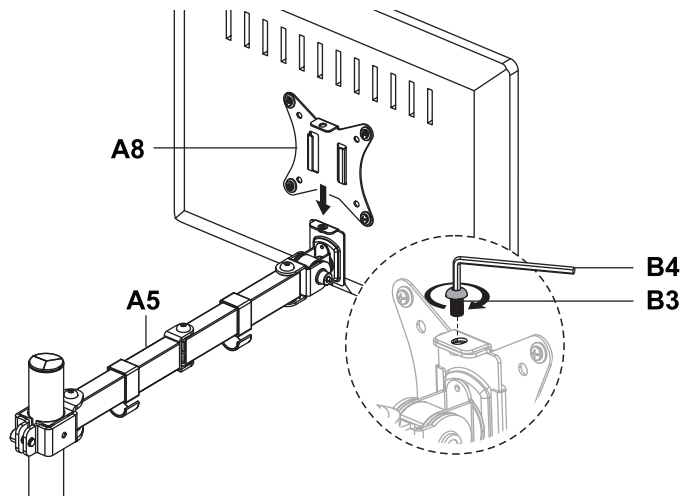

## Step 8: Cable Management

Attach the monitor cables and route them through the installed cable management hooks and cover.

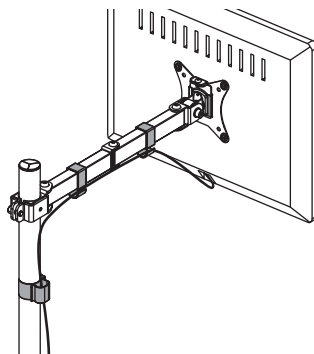

## Step 9: Monitor Arm Range

**CAUTION:** DO NOT use the display beyond the arrow range to avoid tipping.

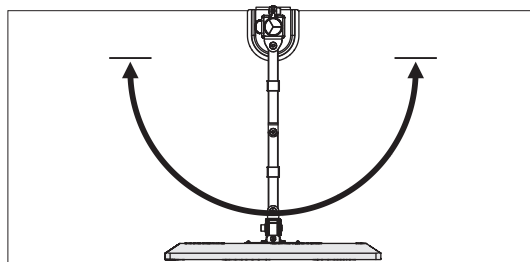

# Assembly & Installation

## Step 10: Adjustability

Adjust the tilt of the monitor using the 6mm Hex Key (B5). Secure the monitor to the desired position by tightening the screw.

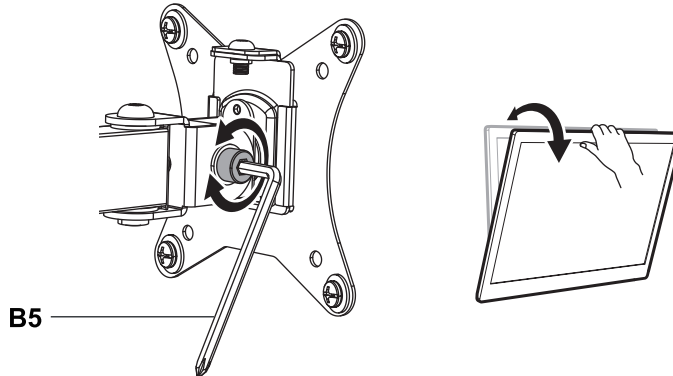

Freely adjust rotation and orientation of the monitor by hand.

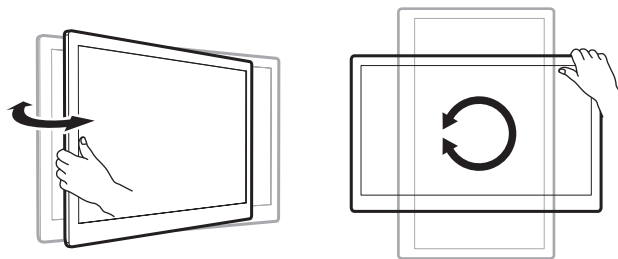

## Step 11: Optional Hex Key Storage

Store the Hex Keys in the Cable Cover (A7) for future adjustments.

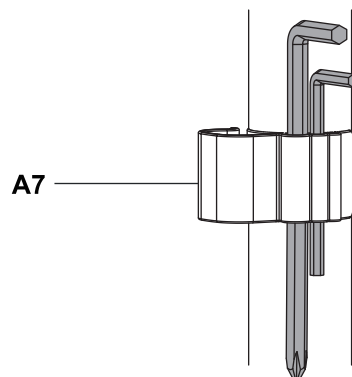

Have any queries? Our expert engineers are here to help!



[sales@progressivedesk.com](mailto:sales@progressivedesk.com)



1-800-828-9414



[progressivedesk.com](http://progressivedesk.com)