



VESA
100×100
75×75

10"-27"

max
5-20 lb

-85°-15°

0.8 - 4.7"



Scan for more information

DM-02-2

User Manual

Table of Contents

Specifications	3
Parts List	4
Assembly & Installation	5
Safety Precautions	7

Specifications

Monitor Compatibility	17" to 27"
Weight Capacity	5 to 20 lbs.
Product Weight	10.14 lbs.
Clamp Desk Thickness	0.79" to 4.72"
Grommet Desk Thickness	0.98" to 3.94"
Grommet Hole Compatibility	0.34" to 3.15"
VESA Compatibility	100mm x 100mm and 75mm x 75mm
Base Rotation	$\pm 135^\circ$
Arm Joint Rotation	$\pm 180^\circ$
Monitor Swivel	$\pm 90^\circ$
Monitor Rotation	$\pm 180^\circ$
Tilt	-85° to $+15^\circ$
Max Height	16.34"
Clamp Mount	Included
Grommet Mount	Included

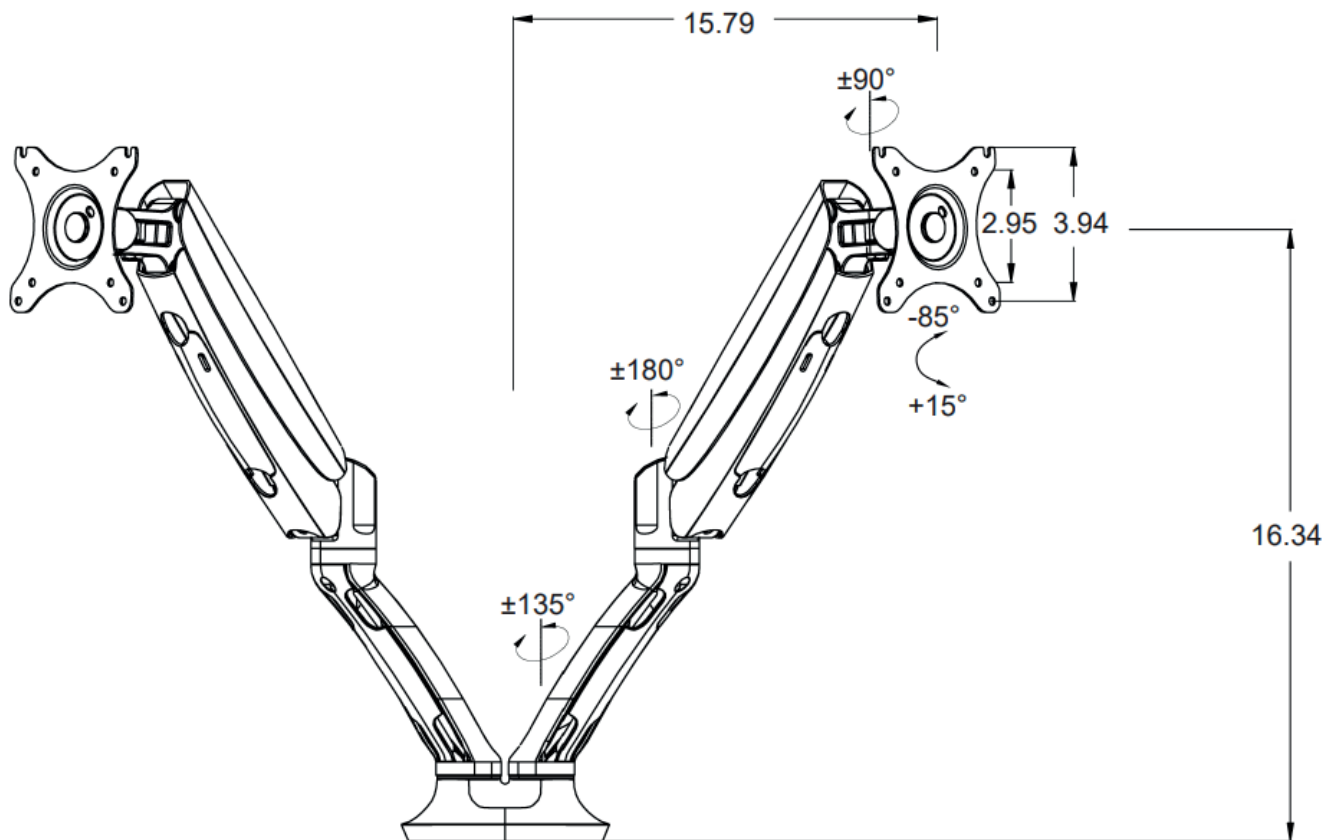

Parts List

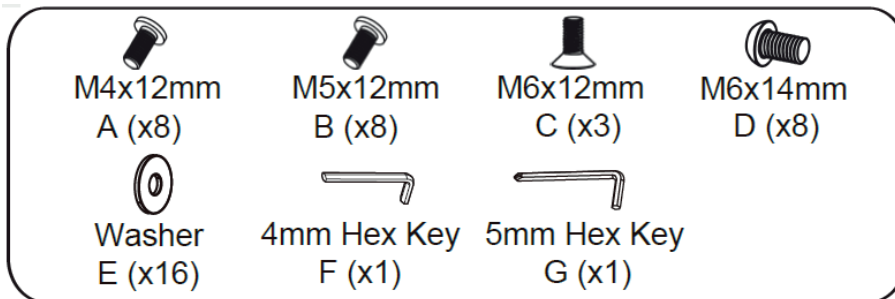

1. Grommet Base Plate (x1)
2. Grommet Screw (x1)
3. Grommet Bottom Plate (x1)
4. Grommet Knob (x1)
5. Clamp Bracket (x1)
6. Clamp (x1)
7. Clamp Cover (x1)
8. Cable Tie (x10)
9. Foam Base Pad (x1)
10. Foam Clamp Pad (x4)
11. Foam Grommet Pad (x1)
12. Monitor Arm Cover (x2)
13. M6 Wrench (x1)
14. Monitor Arm (x1)

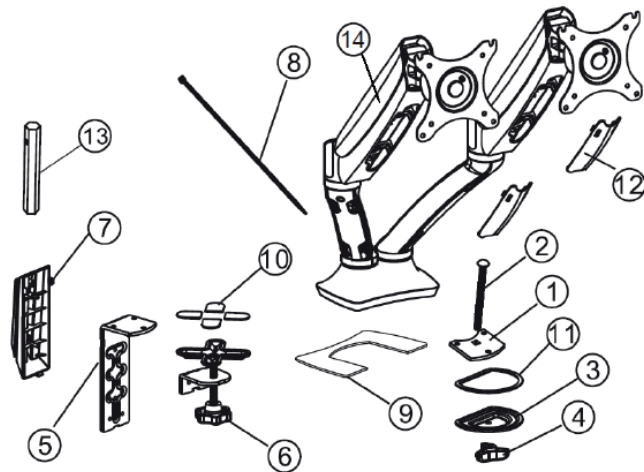

Tools Needed



Assembly & Installation

Step 1: Choose Installation Method (Clamp or Grommet)

Option 1: Clamp – Desk Side Mount

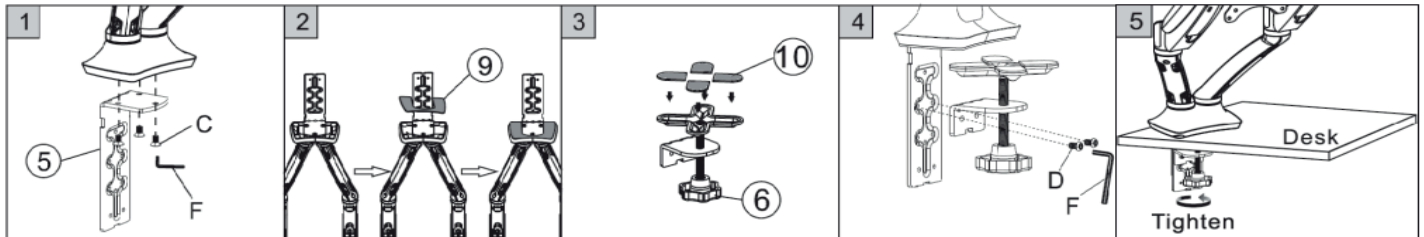

Compatible desk thickness:
0.8" - 4.7"

Option 2: Grommet – Desk Hole Mount

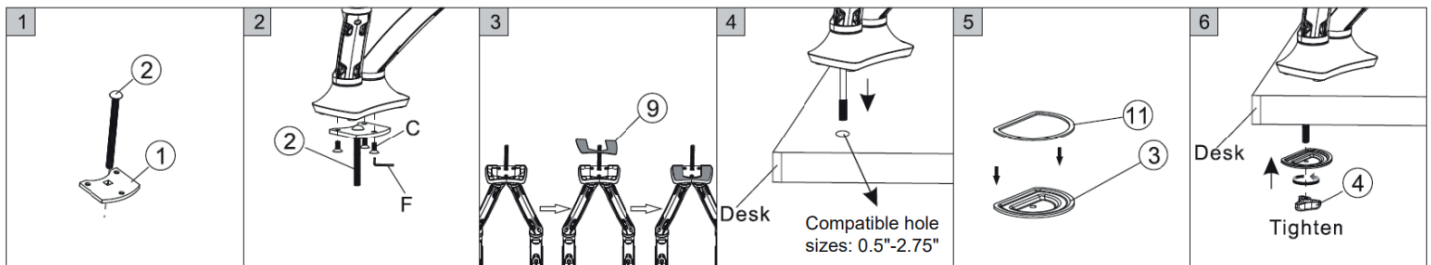

Compatible desk
thickness: 0.98" - 3.94"

Step 2: Monitor Installation

Attach the monitor to the Monitor Arm (14)

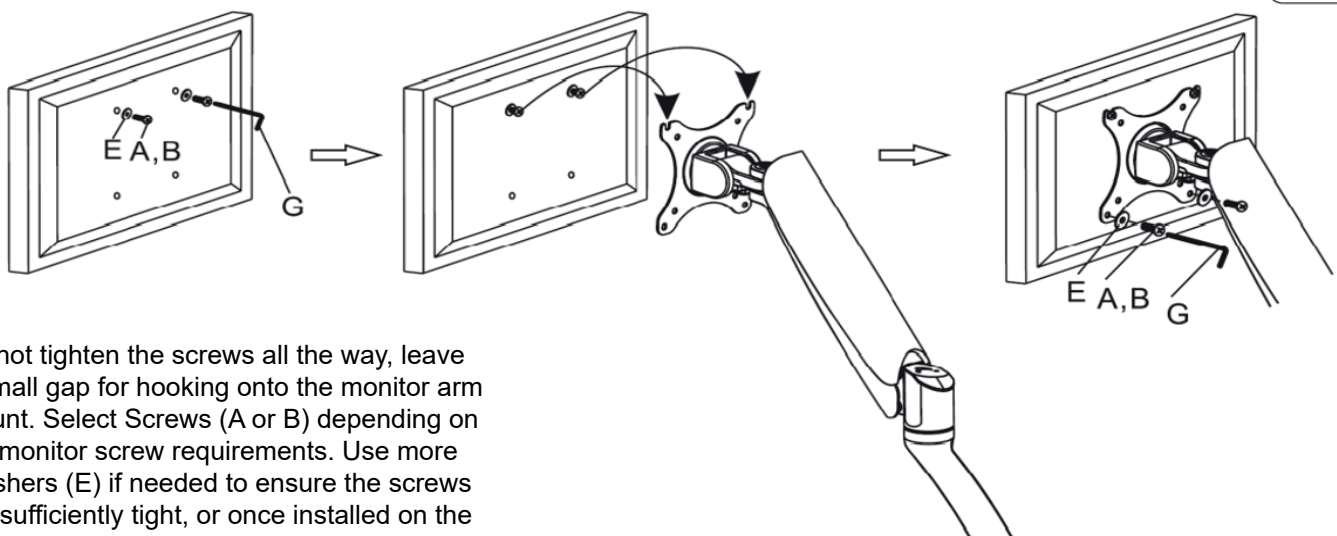
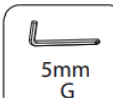

Do not tighten the screws all the way, leave a small gap for hooking onto the monitor arm mount. Select Screws (A or B) depending on the monitor screw requirements. Use more Washers (E) if needed to ensure the screws are sufficiently tight, or once installed on the Monitor Arm (14).

Step 3: Adjust Range of Motion

Adjust the Monitor Arm (14) for both arms

1. Adjust the swivel using the 5mm Hex Key (G).
2. Adjust the tilt using the M6 Wrench (13).
3. Balance the monitor with the Monitor Arm (14) using the 5mm Hex Key (G). Set the monitor to the middle position. If the monitor drifts down, screw in the "+" direction. If the monitor drifts up, screw in the "-" direction. Adjust until it does not drift, then the monitor will be balanced with the arm.

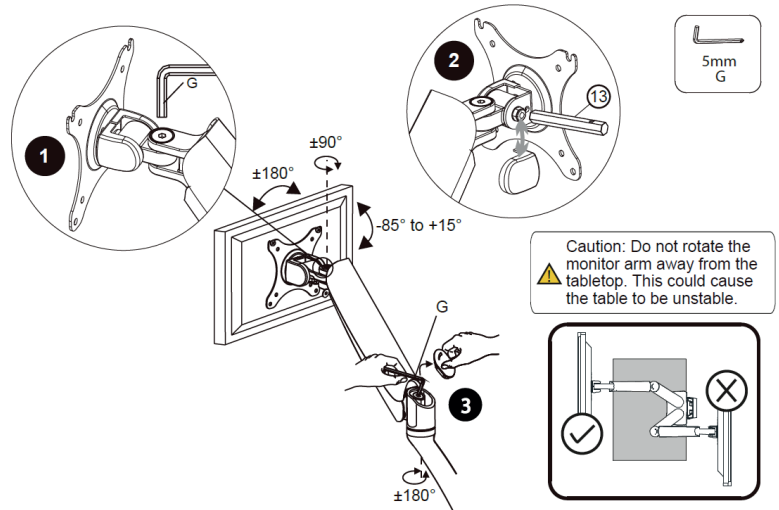

Step 4: Cable Management

Step 4A: Use the Cable Ties (8) to secure the monitor cables together

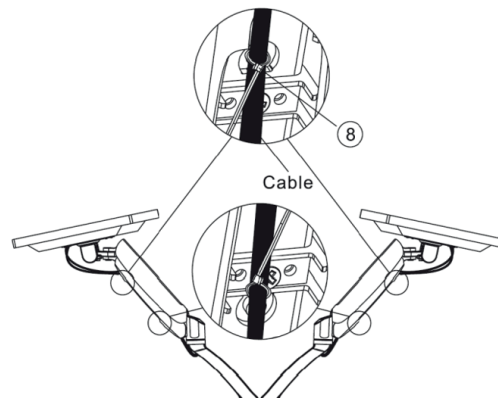

Step 4B: Secure the cables to the Monitor Arm (14) by screwing in the Monitor Arm Covers (12) and attaching the Clamp Cover (7)

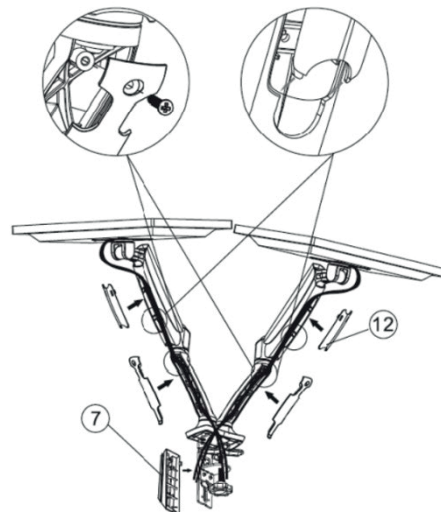

Safety Precautions

- This product contains small items that could be a choking hazard if swallowed. Keep these items away from young children. Please ensure all instructions are read and completely understood before attempting installation. If you are unsure of any part of this installation, please contact a professional installer for assistance.
 - The desk or mounting surface must be capable of supporting the combined weight of the Monitor Stand and monitors, otherwise the structure must be reinforced. To ensure optimal performance, check for any loose screws every two months.
 - This product was designed to be installed onto a tabletop. Before installing, make sure the mount will support the combined load of the mount and display. Never exceed the maximum load capacity of 20 lbs. per arm or this may result in product failure or personal injury.
 - This product is intended for indoor use only. Use of this product outdoors could lead to product failure or personal injury.
- ⚠ WARNING –** This product contains high pressure gas spring parts, please do not put it into fire, high temperatures, or disassemble it, which will lead to unexpected personal injury. Defective products can be sent back to the manufacturer or handed over to professional institutions. To ensure the sealing performance of the gas spring, we recommend that the arm is moved through its full range of motion at least once a month to maintain its long term functionality.



Have any queries? Our expert engineers are here to help!



sales@progressivedesk.com



1-800-828-9414



progressivedesk.com