



Scan for more information

PA-MC1

User Manual

TABLE OF CONTENTS

Safety Precautions	3
Specifications	4
Dimensions (Imperial).....	5
Dimensions (Metric).....	6
Performance Graphs	7
Connectors & Feedback	8

Have any queries? Our expert engineers are here to help!



sales@progressiveautomations.com



1-800-676-6123



progressiveautomations.com

SAFETY PRECAUTIONS

When installing and using your Progressive Automations linear actuator, basic safety precautions should always be followed. Please read all safety precautions thoroughly and be familiar with all functions of the product before use. Apply all other relevant precautions when operating electrical and moving mechanical devices.

DANGER

To reduce the risk of electrical shock and injuries:

- Do not attempt to modify or repair the actuator.
- Avoid using the actuator in environments with explosive gases or flammable materials.
- Avoid using the actuator beyond its specified Ingress Protection rating.
- Make sure that the power source is properly grounded. Neglecting proper grounding can result in a dangerous electrical hazard.

WARNING

To reduce personal harm and injury:

- Follow recommended load ratings and specifications for the actuator.
- Avoid leaving the actuator unattended during operation.
- Avoid operating the actuator in areas with high levels of airborne contaminants.
- Ensure a clear path for full extension and retraction of the actuator.
- Keep hands and body parts clear of the actuator while it is in motion.
- Exercise caution around pinch points and moving components during the actuator's operation.
- Keep all loose clothing, jewelry, and personal items away from the actuator's moving parts.

Operating Notes

Warranty

Any attempts to disassemble or tamper with the actuator's internal components or operation outside of the advertised usage limitations will result in voiding the product's warranty. For more information on our warranty terms, visit:

<https://www.progressiveautomations.com/pages/warranty-terms>

Force Restrictions

Linear actuators must be used within the specified force rating outlined in this documentation. Load must be evenly distributed. Exceeding the recommended force rating may result in failure of the linear actuator. It may also damage the product and void the warranty. Please note that the weight of the load does not always equal the total force due to mechanical advantage, wherein the force may increase or decrease depending on the application.

Operation Time

Linear actuators must be operated within the specified operation time and frequency. Exceeding the duty cycle rating can significantly reduce the actuator's expected lifespan and will void the warranty.

SPECIFICATIONS

Rated Load Configurations (Imperial)

Rated Load (lbs)		Current (mA)		Speed ¹ (inch/sec)	
Dynamic	Static ²	No Load	Full Load	No Load	Full Load
8	≥ 4.5	≤ 300	≤ 800	1.89	1.12
11	≥ 9.0	≤ 300	≤ 700	1.18	0.77
17	≥ 13.5	≤ 300	≤ 550	0.69	0.45
39	≥ 31.0	≤ 300	≤ 700	0.43	0.24

Rated Load Configurations (Metric)

Rated Load (N)		Current (mA)		Speed ¹ (mm/sec)	
Dynamic	Static ²	No Load	Full Load	No Load	Full Load
35	≥ 20	≤ 300	≤ 800	48	28.5
50	≥ 40	≤ 300	≤ 700	30	19.5
75	≥ 60	≤ 300	≤ 550	17.5	11.5
175	≥ 140	≤ 300	≤ 700	10.8	6.1

¹ Speed specifications have a ±10% tolerance.

² Static force is the same with or without motor lock/brake from control box.

Specifications

	Imperial	Metric
Input Voltage	12 VDC	
Stroke	0.5" to 8.0"	13 mm to 203 mm
Feedback	None or Potentiometer Feedback	
Duty Cycle	20% (2 minutes on, 8 minutes off)	
Weather Protection	IP65	
Overload Protection	Yes – Built-in Current Detection (Standard only)	
PWM Compatibility	No	
Operational Temperature	14°F to 122°F	-10°C to 50°C
Operating Noise	< 60 dBA from 1.5 ft.	< 60 dBA from 450 mm
Limit Switch	Yes – Flexible Circuit Type	
Cable Length	12"	300 mm
Connector	2-Pin Molex SL Connector (Standard) 5-Pin Molex SL Connector (Potentiometer)	
Front Mounting Hole Size	0.16"	4.10 mm
Rear Mounting Hole Size	0.16"	4.10 mm
Actuator Type	Micro	
Motor Type	Brushed DC Motor	
Screw Type	ACME	
Stroke Rod Material	Grade 45 Steel	
Housing Material	PA66-GF35	
Certifications	UL Recognized Component, RoHS Compliant, California Proposition 65 Compliant	
Compatible Mounting Brackets	BRK-MC1	

DIMENSIONS (IMPERIAL)

Note: All dimensions are listed in inches.

Diagram

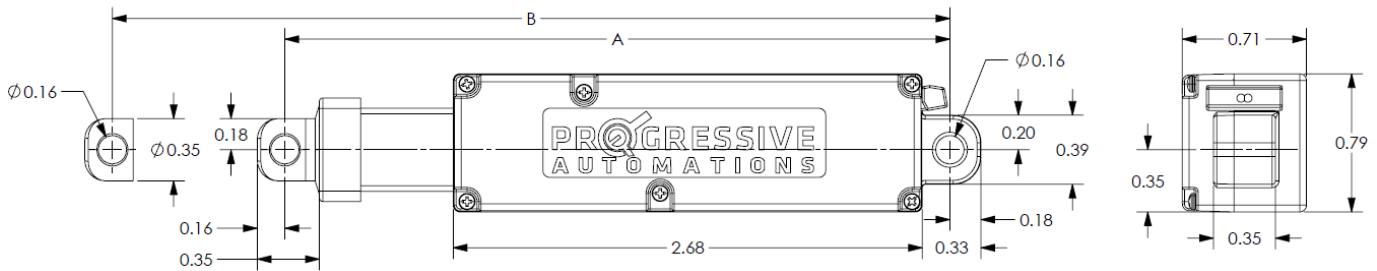
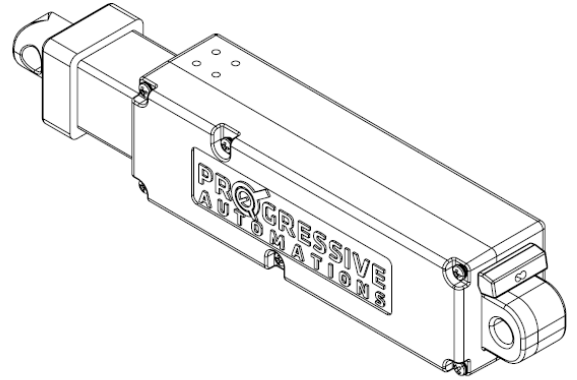

Hole to Hole Length

Stroke Length	0.5"	1"	2"	4"	6"	8"
A (Fully Retracted)	3.30	3.80	4.80	6.80	8.80	10.80
B (Fully Extended)	3.80	4.80	6.80	10.80	14.80	18.80

0.5" ≤ Stroke Length ≤ 8"

A (Fully Retracted) = Stroke Length + 2.80"

B (Fully Extended) = Stroke Length x 2 + 2.80"

DIMENSIONS (METRIC)

Note: All dimensions are listed in millimeters.

Diagram

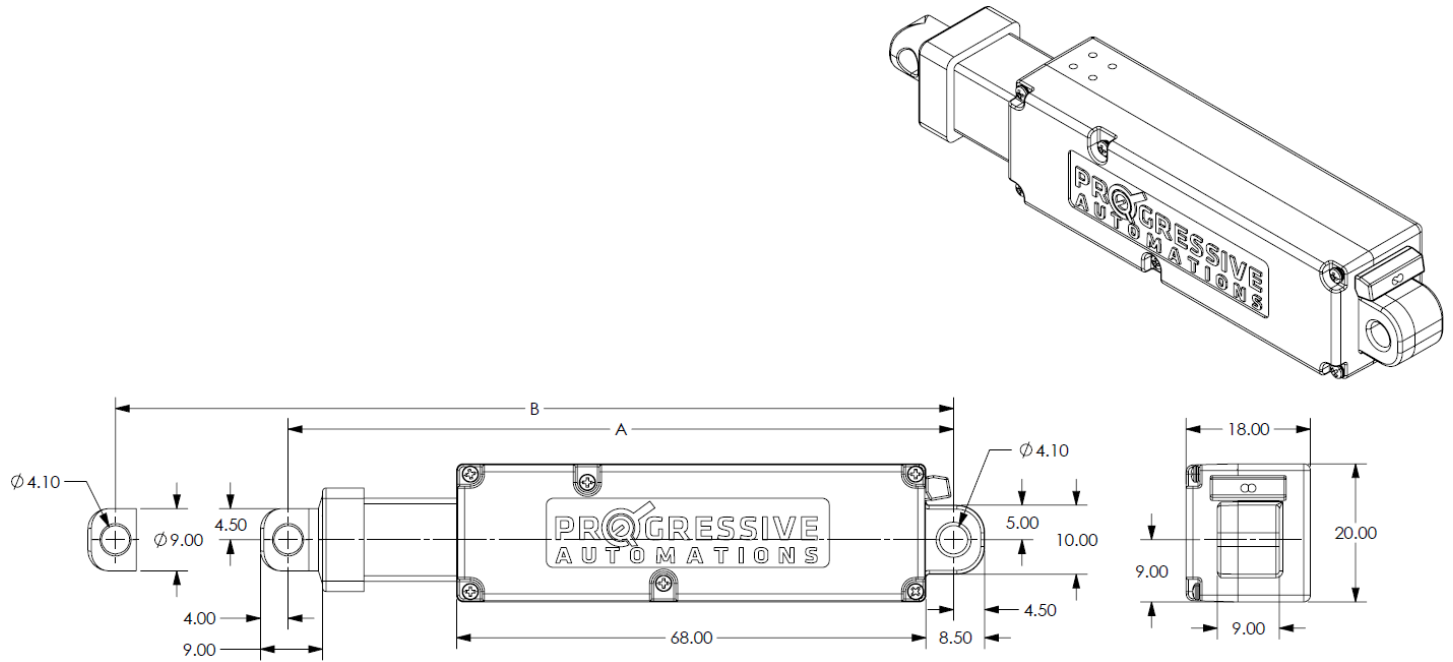

Hole to Hole Length

Stroke Length	13 mm	25 mm	51 mm	102 mm	152 mm	203 mm
A (Fully Retracted)	84	96	122	173	223	274
B (Fully Extended)	97	121	173	275	375	477

13 mm ≤ Stroke Length ≤ 203 mm

A (Fully Retracted) = Stroke Length + 71 mm

B (Fully Extended) = Stroke Length x 2 + 71 mm

PERFORMANCE GRAPHS

Speed vs. Load

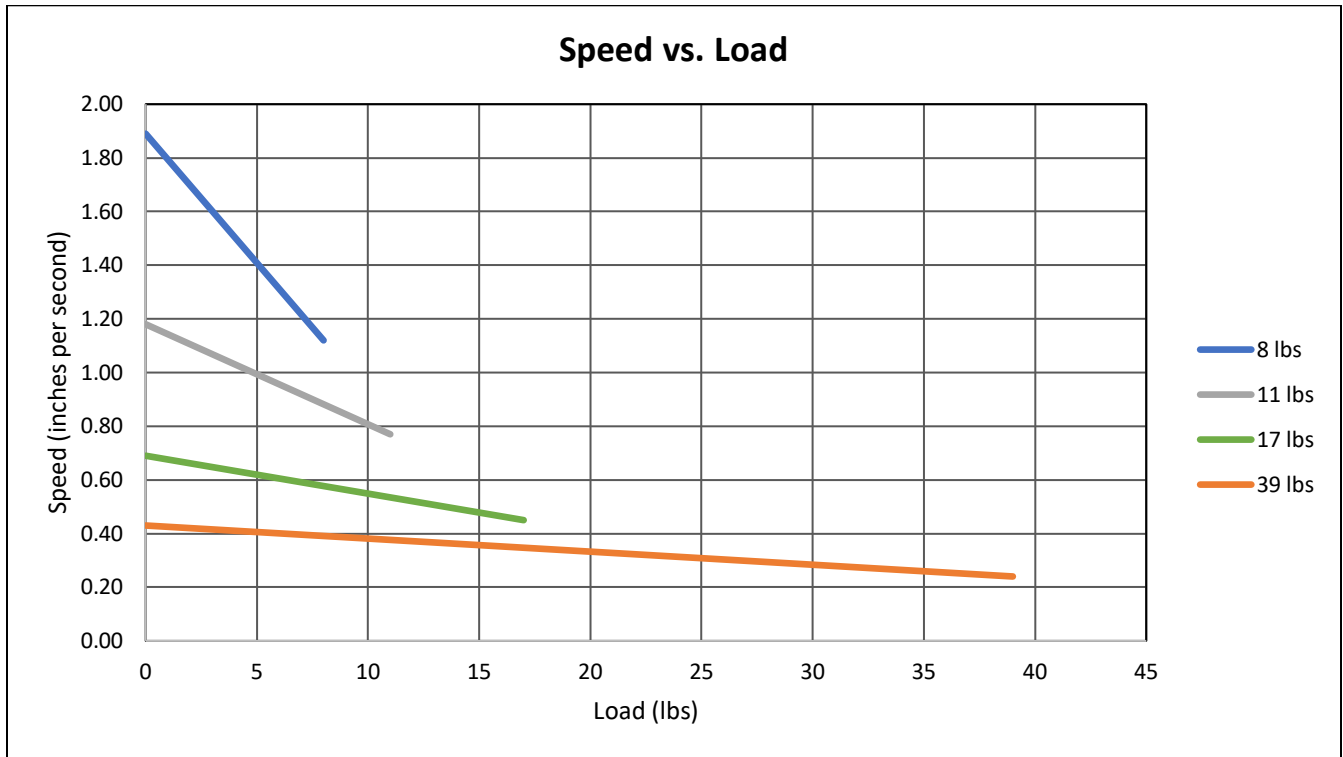

Current vs. Load

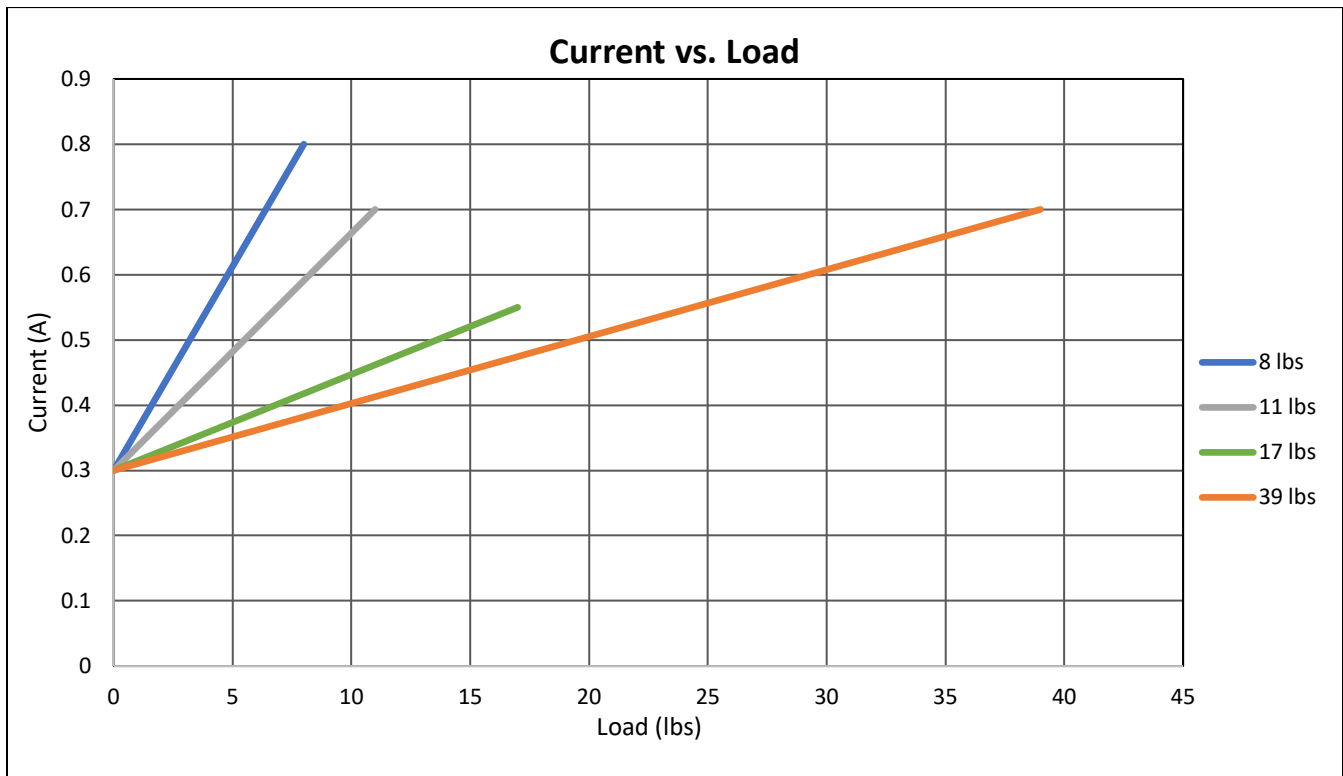

CONNECTORS & FEEDBACK

Standard – 2-Pin Connector

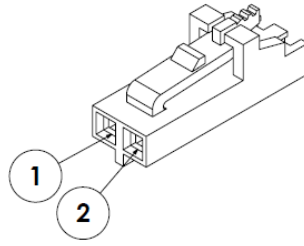

Pin Location	1	2
Function	Motor - (Retract)	Motor + (Extend)
Wire Color	Black	Red
Wire Gauge	26 AWG	26 AWG

	Part Name	Part Number	Mating Part Number
Housing	SL Crimp Housing, Single Row, Version G, Positive Latch, 2 Circuits, Black	50579402	701070001
Terminal	SL Crimp Terminal, Series 70058, Female, 30-24 AWG, with Tin (Sn) Plated Contact	16020069 (Reel) 16020096 (Bag)	16020107 (Reel) 16020114 (Bag)

Potentiometer – 5-Pin Connector

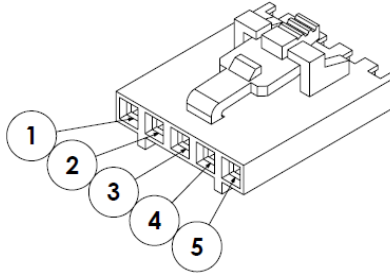

Pin Location	1	2	3	4	5
Function	Potentiometer VCC	Motor - (Retract)	Motor + (Extend)	Potentiometer Wiper	Potentiometer GND
Wire Color	Yellow	Black	Red	Purple	Orange
Wire Gauge	26 AWG	26 AWG	26 AWG	26 AWG	26 AWG

	Part Name	Part Number	Mating Part Number
Housing	SL Crimp Housing, Single Row, Version G, Positive Latch, 5 Circuits, Black	50579405	701070004
Terminal	SL Crimp Terminal, Series 70058, Female, 30-24 AWG, with Tin (Sn) Plated Contact	16020069 (Reel) 16020096 (Bag)	16020107 (Reel) 16020114 (Bag)

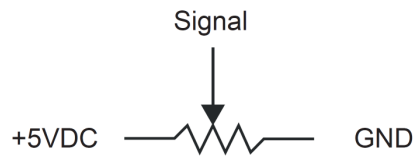

Signal Output	Tolerance
2540 Ω /inch (100 Ω /mm)	$\pm 5\%$