



Scan for more information

# PA-MC1

---

## User Manual

# TABLE OF CONTENTS

Safety Precautions .....	3
Specifications .....	4
Dimensions.....	5
Performance Graphs .....	6
Connectors & Feedback .....	7

**Have any queries? Our expert engineers are here to help!**



[sales@progressiveautomations.com](mailto:sales@progressiveautomations.com)



1-800-676-6123



[progressiveautomations.com](http://progressiveautomations.com)

# SAFETY PRECAUTIONS

When installing and using your Progressive Automations linear actuator, basic safety precautions should always be followed. Please read all safety precautions thoroughly and be familiar with all functions of the product before use. Apply all other relevant precautions when operating electrical and moving mechanical devices.

## DANGER

To reduce the risk of electrical shock and injuries:

- Do not attempt to modify or repair the actuator.
- Avoid using the actuator in environments with explosive gases or flammable materials.
- Avoid using the actuator beyond its specified Ingress Protection rating.
- Make sure that the power source is properly grounded. Neglecting proper grounding can result in a dangerous electrical hazard.

## WARNING

To reduce personal harm and injury:

- Follow recommended load ratings and specifications for the actuator.
- Avoid leaving the actuator unattended during operation.
- Avoid operating the actuator in areas with high levels of airborne contaminants.
- Ensure a clear path for full extension and retraction of the actuator.
- Keep hands and body parts clear of the actuator while it is in motion.
- Exercise caution around pinch points and moving components during the actuator's operation.
- Keep all loose clothing, jewelry, and personal items away from the actuator's moving parts.

## OPERATING NOTES

### **Warranty**

Any attempts to disassemble or tamper with the actuator's internal components or operation outside of the advertised usage limitations will result in voiding the product's warranty. For more information on our warranty terms, visit: <https://www.progressiveautomations.com/pages/warranty-terms>

### **Force Restrictions**

Linear actuators must be used within the specified force rating outlined in this documentation. Load must be evenly distributed. Exceeding the recommended force rating may result in failure of the linear actuator. It may also damage the product and void the warranty. Please note that the weight of the load does not always equal the total force due to mechanical advantage, wherein the force may increase or decrease depending on the application.

### **Operation Time**

Linear actuators must be operated within the specified operation time and frequency. Exceeding the duty cycle rating can significantly reduce the actuator's expected lifespan and will void the warranty.

# SPECIFICATIONS

## RATED LOAD CONFIGURATIONS

Rated Load (lbf)		Current (mA)		Speed <sup>1</sup> (inch/sec)	
Dynamic	Static	No Load	Full Load	No Load	Full Load
8	8	≤ 200	≤ 700	1.85	1.18
11	15	≤ 200	≤ 550	1.18	0.75
17	24	≤ 200	≤ 500	0.71	0.51
39	56	≤ 200	≤ 600	0.31	0.24

<sup>1</sup> Speed specifications have a ±10% tolerance.

## SPECIFICATIONS

<b>Input Voltage</b>	12 VDC
<b>Stroke</b>	0.5" to 8.0"
<b>Feedback</b>	None
<b>Duty Cycle</b>	20% (5 minutes on, 20 minutes off)
<b>Weather Protection</b>	IP65
<b>Overload Protection<sup>1</sup></b>	Yes
<b>PWM Compatibility</b>	No
<b>Operational Temperature</b>	-10°C to 50°C (14°F to 122°F)
<b>Operating Noise</b>	<60 dBA from 1.5 ft.
<b>Limit Switch<sup>1</sup></b>	Yes
<b>Cable Length</b>	12"
<b>Connector</b>	2.54mm 2-Pin Female Connector (Standard)
<b>Front Mounting Hole Size</b>	0.16"
<b>Rear Mounting Hole Size</b>	0.16"
<b>Actuator Type</b>	Micro
<b>Motor Type</b>	Brushed DC Motor
<b>Screw Type</b>	ACME
<b>Stroke Rod Material</b>	Stainless Steel
<b>Housing Material</b>	PA66-GF35
<b>Compatible Mounting Brackets</b>	BRK-MC1

<sup>1</sup> Standard Models feature a current detection circuit that automatically halts the actuator at end-of-travel limits.

# DIMENSIONS

**Note:** All dimensions are listed in inches.

## DIAGRAM

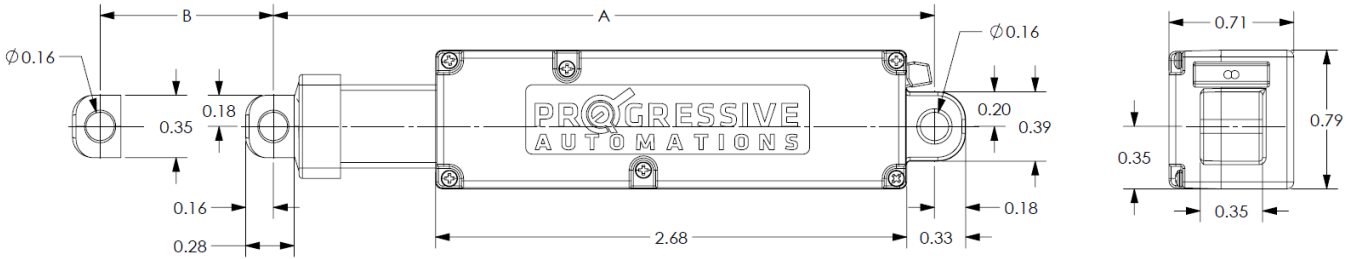
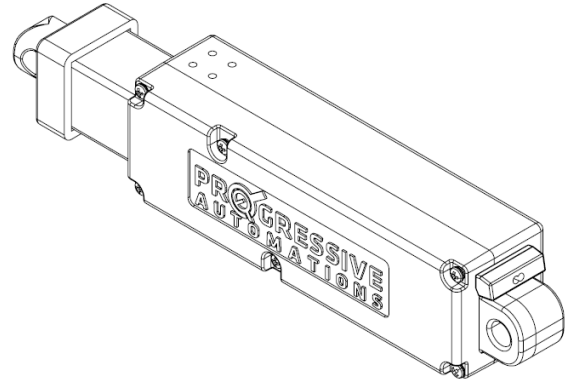

## HOLE TO HOLE LENGTH

Stroke Length	0.5"	1"	2"	4"	6"	8"
<b>A (Fully Retracted)</b>	3.26	3.76	4.76	6.76	8.76	10.76
<b>B (Fully Extended)</b>	3.76	4.76	6.76	10.76	14.76	18.76

**0.5" ≤ Stroke Length ≤ 8"**

A (Fully Retracted) = Stroke Length + 2.76"

B (Fully Extended) = Stroke Length + Stroke Length + 2.76"

# PERFORMANCE GRAPHS

## SPEED VS LOAD

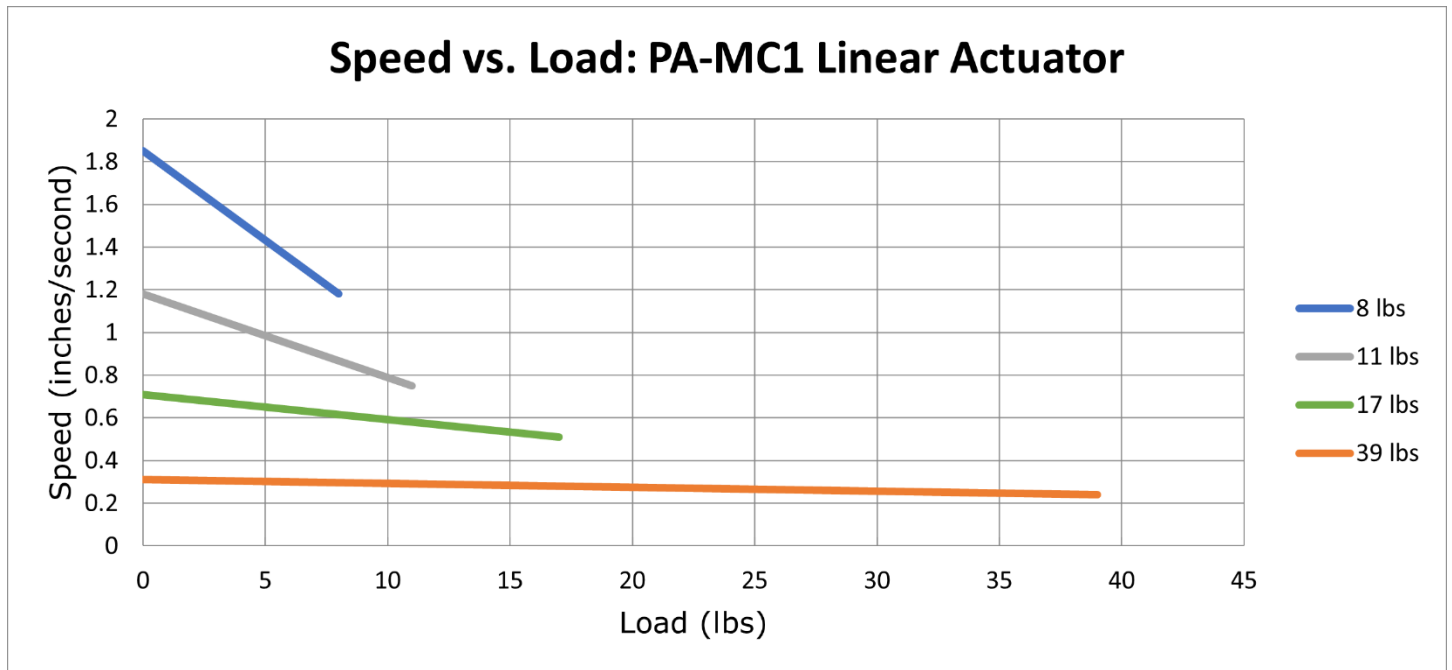

## CURRENT VS LOAD

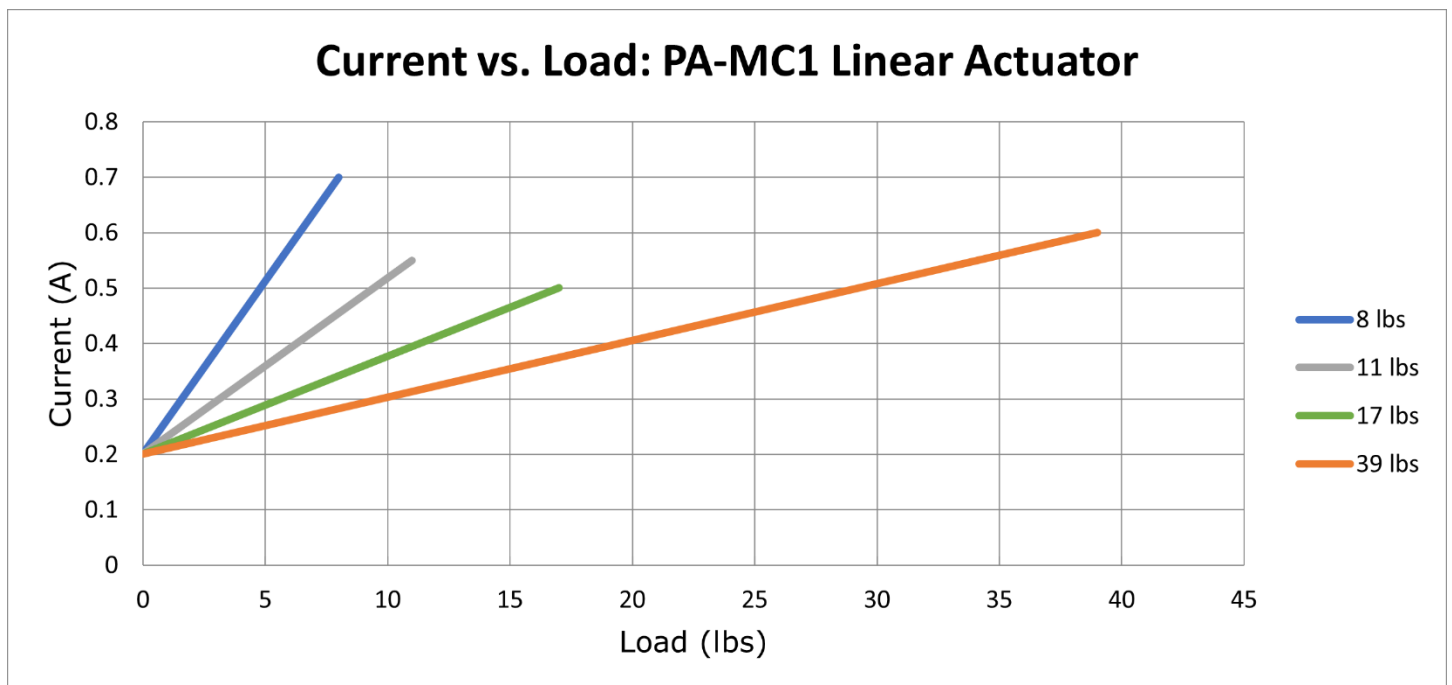

# CONNECTORS & FEEDBACK

## STANDARD – 2-PIN CONNECTOR

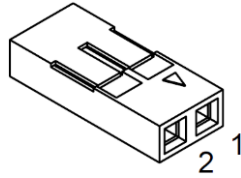

Pin Location	2	1
<b>Function</b>	Motor - (Retract)	Motor + (Extend)
<b>Wire Color</b>	Black	Red
<b>Wire Gauge</b>	26 AWG	26 AWG

	Part Name	Part Number	Mating Part Number
<b>Housing</b>	2.54mm Pitch Connector, 2-Position	2-Pos TJC8	2-Pos TJC8
<b>Terminal</b>	2.54mm Pitch Connector, Female Terminal, 28-22 AWG	HX25402-PT	HX25402-RT

## POTENTIOMETER FEEDBACK – 5-PIN CONNECTOR

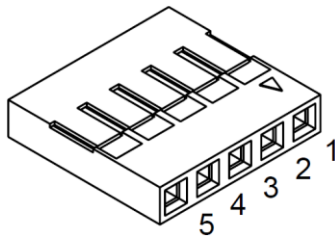

Pin Location	5	4	3	2	1
<b>Function</b>	Potentiometer VCC	Motor - (Retract)	Motor + (Extend)	Potentiometer Wiper	Potentiometer COM
<b>Wire Color</b>	Yellow	Black	Red	Purple	Orange
<b>Wire Gauge</b>	26 AWG	26 AWG	26 AWG	26 AWG	26 AWG

	Part Name	Part Number	Mating Part Number
<b>Housing</b>	2.54mm Pitch Connector, 5-Position, Housing	5-Pos TJC8	5-Pos TJC8
<b>Terminals</b>	2.54mm Pitch Connector, Female Terminal, 28-22 AWG	HX25402-PT	HX25402-RT