



Scan for more information

PA-01

User Manual

TABLE OF CONTENTS

Safety Precautions	3
Specifications	4
Dimensions.....	5
Performance Graphs	6
Connectors	7

Have any queries? Our expert engineers are here to help!



sales@progressiveautomations.com



1-800-676-6123



progressiveautomations.com

SAFETY PRECAUTIONS

When installing and using your Progressive Automations linear actuator, basic safety precautions should always be followed. Please read all safety precautions thoroughly and be familiar with all functions of the product before use. Apply all other relevant precautions when operating electrical and moving mechanical devices.

DANGER

To reduce the risk of electrical shock and injuries:

- Do not attempt to modify or repair the actuator.
- Avoid using the actuator in environments with explosive gases or flammable materials.
- Avoid using the actuator beyond its specified Ingress Protection rating.
- Make sure that the power source is properly grounded. Neglecting proper grounding can result in a dangerous electrical hazard.

WARNING

To reduce personal harm and injury:

- Follow recommended load ratings and specifications for the actuator.
- Avoid leaving the actuator unattended during operation.
- Avoid operating the actuator in areas with high levels of airborne contaminants.
- Ensure a clear path for full extension and retraction of the actuator.
- Keep hands and body parts clear of the actuator while it is in motion.
- Exercise caution around pinch points and moving components during the actuator's operation.
- Keep all loose clothing, jewelry, and personal items away from the actuator's moving parts.

OPERATING NOTES

Warranty

Any attempts to disassemble or tamper with the actuator's internal components or operation outside of the advertised usage limitations will result in voiding the product's warranty. For more information on our warranty terms, visit:

<https://www.progressiveautomations.com/pages/warranty-terms>

Force Restrictions

Linear actuators must be used within the specified force rating outlined in this documentation. Load must be evenly distributed. Exceeding the recommended force rating may result in failure of the linear actuator. It may also damage the product and void the warranty. Please note that the weight of the load does not always equal the total force due to mechanical advantage, wherein the force may increase or decrease depending on the application.

Operation Time

Linear actuators must be operated within the specified operation time and frequency. Exceeding the duty cycle rating can significantly reduce the actuator's expected lifespan and will void the warranty.

SPECIFICATIONS

RATED LOAD CONFIGURATIONS

Rated Load (lbf)		12 VDC Current (A)		24 VDC Current (A)		12 VDC Speed ¹ (inch/sec)		24 VDC Speed ¹ (inch/sec)	
Dynamic	Static	No Load	Full Load	No Load	Full Load	No Load	Full Load	No Load	Full Load
16	16	1.5	4.0	0.8	2.0	3.54	2.66	3.54	2.95
28	28	1.5	4.0	0.8	2.0	1.89	1.38	1.89	1.50
56	56	1.5	4.0	0.8	2.0	1.38	1.02	1.38	1.14
112	112	1.5	4.0	0.8	2.0	0.94	0.67	0.94	0.71
169	169	1.5	4.0	0.8	2.0	0.39	0.30	0.39	0.31
225	225	1.5	4.0	0.8	2.0	0.28	0.20	0.28	0.20

¹Speed specifications have a $\pm 10\%$ tolerance.

SPECIFICATIONS

Input Voltage	12 VDC or 24 VDC
Stroke	1.0" to 40.0"
Feedback	None, Hall Effect Sensor
Duty Cycle	25% (5 minutes on, 15 minutes off)
Weather Protection	IP65
Operational Temperature	5°C to 40°C (41°F to 104°F)
Operating Noise	≤45 dBA from 5 ft. at no load. ≤50 dBA from 5 ft. at full load
Limit Switch	Built-In (Non-Adjustable)
Cable Length	40" (Customizable)
Connector	Molex Mini-Fit Jr 2-Pin (Standard), Molex Mini-Fit Jr 6-Pin (Hall Effect Sensor)
Front Mounting Hole Size	0.25"
Rear Mounting Hole Size	0.25"
Actuator Type	Mini, Industrial
Motor Type	Brushed DC Motor
Screw Type	ACME
Stroke Rod Material	Stainless Steel
Housing Material	Aluminum Alloy 6062
Gear Material	Polyformaldehyde/Powder Metallurgy Steel Alloy
Compatible Mounting Brackets	BRK-14

DIMENSIONS

Note: All dimensions are listed in inches.

DIAGRAM

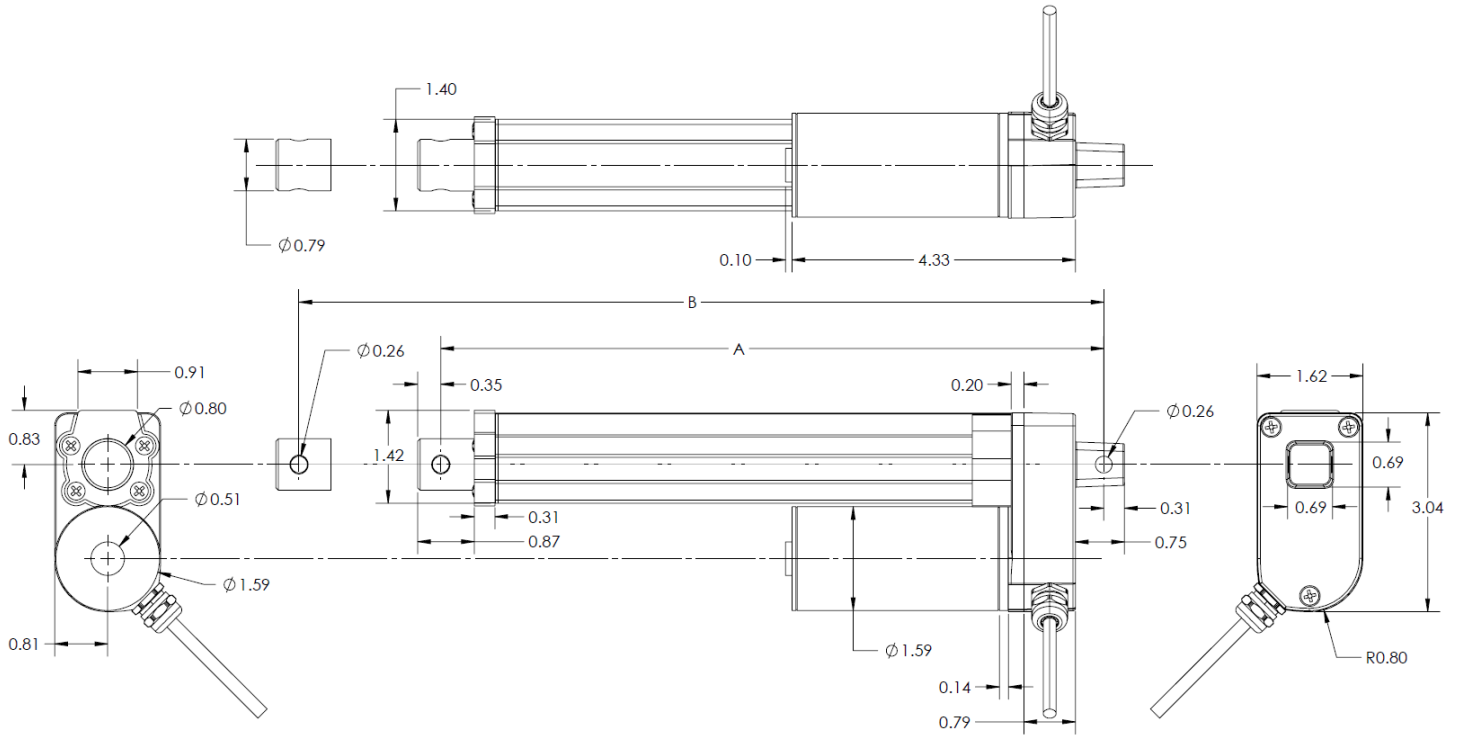

HOLE TO HOLE LENGTH

Stroke Length	1"	2"	3"	4"	6"	8"	9"	10"	12"	18"	24"	30"	40"
A (Fully Retracted)	5.13	6.13	7.13	8.13	10.13	12.13	13.13	14.13	16.13	22.13	28.13	34.72	45.51
B (Fully Extended)	6.13	8.13	10.13	12.13	16.13	20.13	22.13	22.13	28.13	40.13	52.13	64.72	85.51

1" ≤ Stroke Length ≤ 24"

A (Fully Retracted) = Stroke Length + 4.13"

B (Fully Extended) = Stroke Length x 2 + 4.13"

24" < Stroke Length ≤ 30.12"

A (Fully Retracted) = Stroke Length + 4.72"

B (Fully Extended) = Stroke Length x 2 + 4.72"

30.12" < Stroke Length ≤ 40"

A (Fully Retracted) = Stroke Length + 5.51"

B (Fully Extended) = Stroke Length x 2 + 5.51"

PERFORMANCE GRAPHS

SPEED VS LOAD

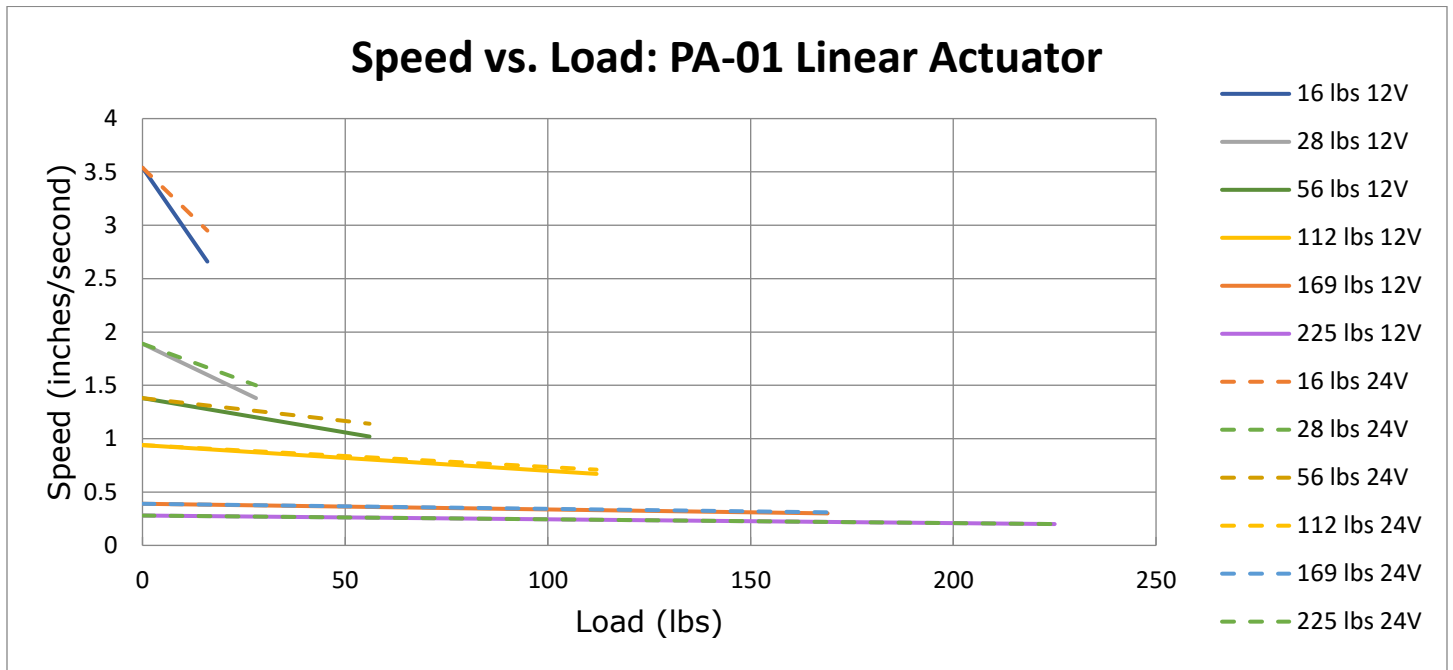

CURRENT VS LOAD

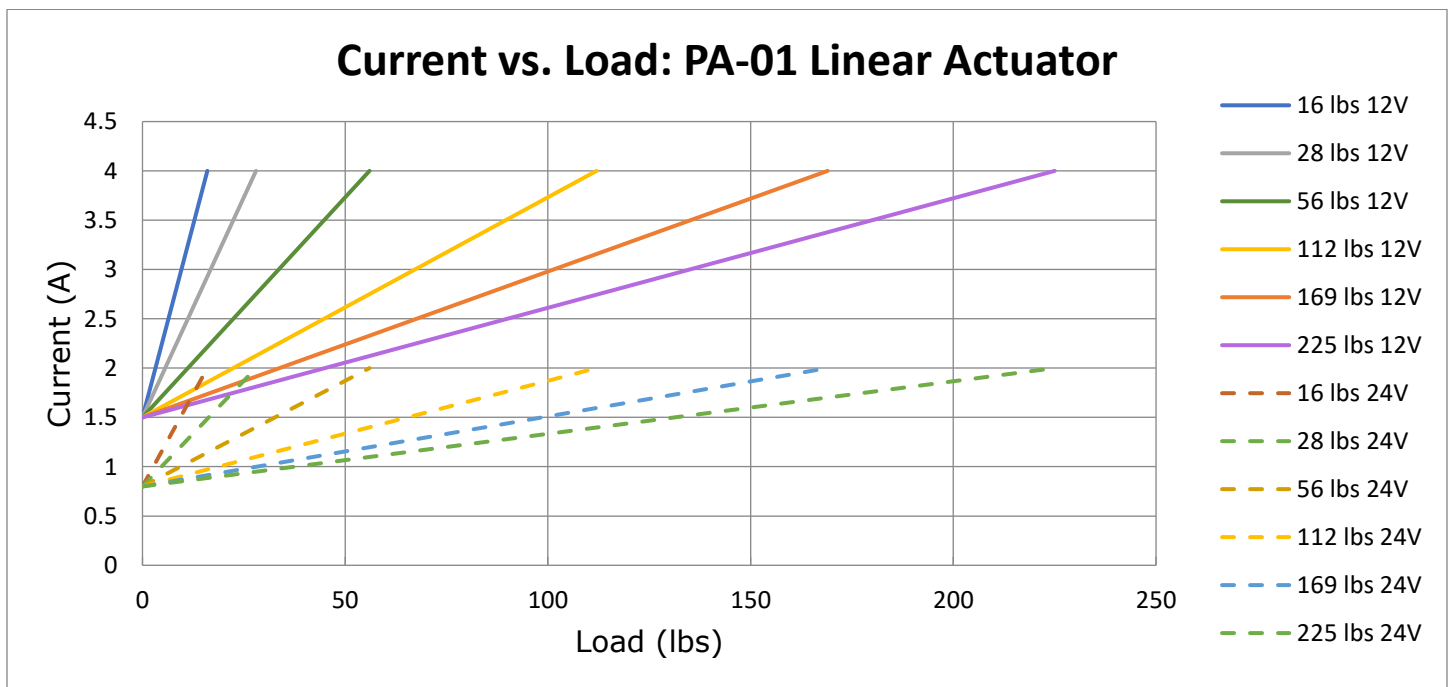

CONNECTORS

STANDARD - 2-PIN CONNECTOR

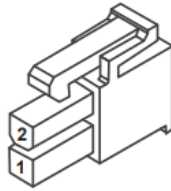

Pin Location	1	2
Function	Motor - (Retract)	Motor + (Extend)
Wire Color	Black	Red
Wire Gauge	20 AWG	20 AWG

	Force (lbf)	Part Name	Part Number	Mating Part Number
Housing	All	Molex Mini-Fit Jr. Receptacle Housing, 2-Row	39-01-2025	39-01-3029 /39-01-2026
Terminals	All	Molex Mini-Fit Jr. Female Terminal, 18-24 AWG	39-00-0038	39-00-0040